

# Model No. PF1110 POMPE SUB A EAU CHARGE E1100W

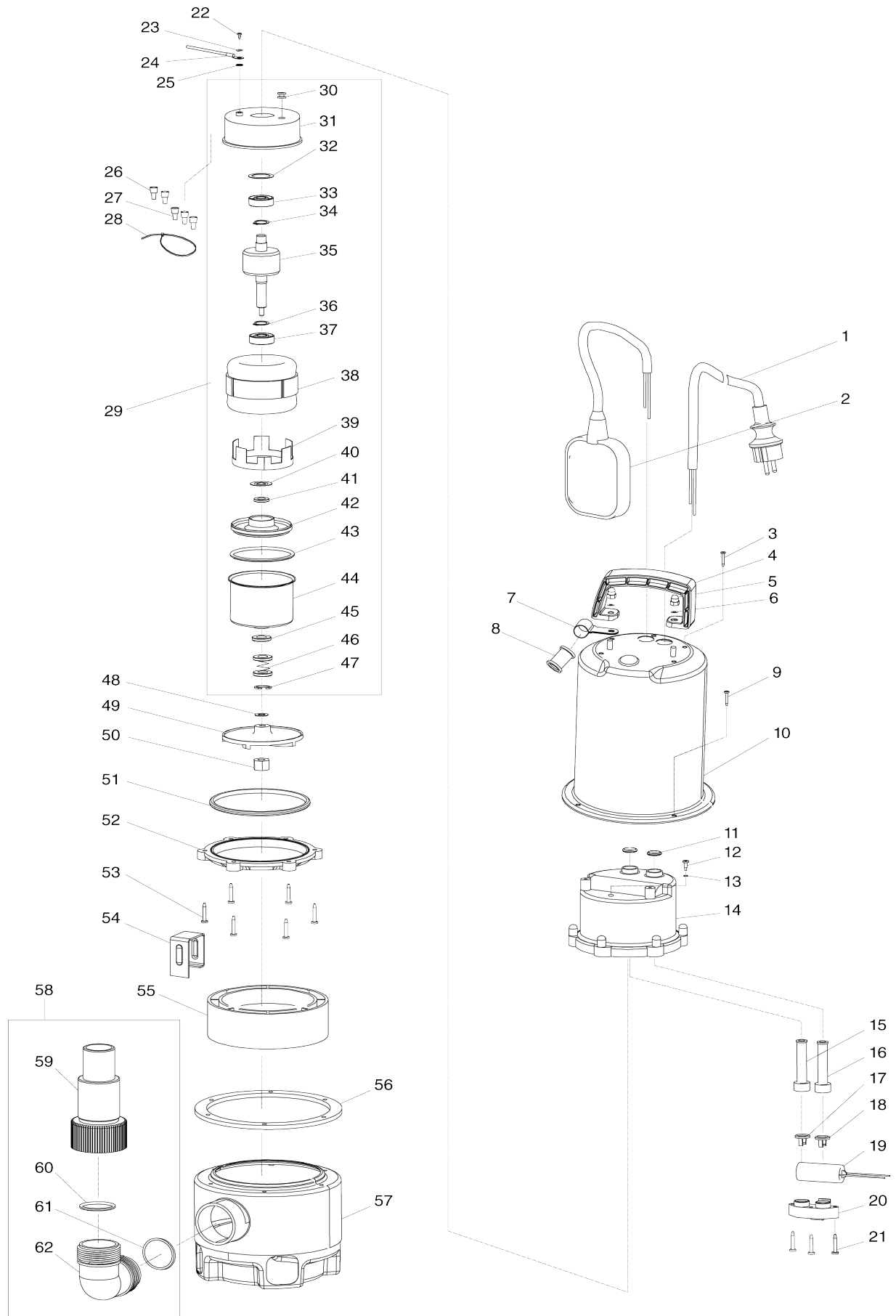

Model No.PF1110 POMPE SUB A EAU CHARGE1100W

Numéro d'article	N ° de pièces	Description	Interchangeabilité	Q'ty	Nouvelle / ancienne	Note 1	Note 2
001	609025435	POWER SUPPLY CORD 1.0-3-10		1	*		
001-1	JH00000123	CORD H07RN-F 1.0-3-10 EU	<	1	*		
001-2	JH00000196	CORD H07RN-F 1.0-3-10 EU	O	1			
002	609026209	FLOAT SWITCH BLUE		1	*		
002-1	JH00000126	FLOAT SWITCH BLUE	<	1	*		
002-2	JH00000198	FLOAT SWITCH BLUE	O	1			
003	609026213	TAPPING SCREW 4.2X13 INOX		5	*		
003-1	JH00000077	Y HEAD TAPPING SCREW ST4.5X13	<	5			
004	609024798	HANDLE BLUE		1			
005	609024637	HEX. CAP NUT M5 INOX		2			
006	609024638	FLAT WASHER 5 INOX		2			
007	609024650	CORD CLAMP INOX		1			
008	609026214	CORD GUARD		1			
009	609024639	+ PAN HEAD SCREW M4X10 INOX		6			
010	JH00000063	UPPER HOUSING INOX		1			
C10	609024674	BLIND PLUG		1			
011	609024641	O-RING 15		2	*		
011-1	JH00000117	O-RING 15	<	2			
012	JH00000002	TAPPING SCREW		1			
013	JH00000003	O-RING		1	*		
013-1	JH00000125	O-RING	O	1			
014	609024642	WATER PROOF INNER HOUSING		1			
015	609024588	CORD GUARD 8.5		1	*		
015-1	JH00000110	CORD GUARD 8.5	<	1			
016	609024588	CORD GUARD 8.5		1	*		
016-1	JH00000110	CORD GUARD 8.5	<	1			
017	609024590	CORD CLAMP 8.5		1			
018	609024590	CORD CLAMP 8.5		1			
019	JH00000045	CONDENSATEUR		1	*		
019-1	JH00000182	CAPACITOR 16 MICRO F	O	1			
020	609024592	CAPACITOR HOLDER		1			
021	609024593	TAPPING SCREW 4X32		3			
022	609024601	SCREW M4X8		1			
023	609024596	SPRING WASHER 4		1			
024	JH00000004	GROUND WIRE ASSY		1			
025	609024600	TOOTHED LOCK SPRING WASHER 4		1	*		
025-1	JH00000082	TOOTHED LOCK SPRING WASHER 4	<	1			
026	609024629	CLOSED END SPLICE 5.5-SD		2			
027	609024630	CLOSED END SPLICE 2-SD		3			
028	609024632	CABLE TIE		1			
029	JH00000071	JEU DE REPARATION MOTEUR		1			
D10		INC. 30-47					
D11		INC. 30-33,35,37-47					
030	609024595	GROMMET 10		1			
031	609024594	MOTOR HOUSING UPPER SIDE		1			

032	609024602	WAVE WASHER 25		1		
033	609024603	BALL BEARING 6201Z		1		
034	961052-5	Circlip exterieur S-12		1	*	
035	JH00000053	ROTOR		1		
036	961052-5	Circlip exterieur S-12		1	*	
037	609024603	BALL BEARING 6201Z		1		
038	JH00000054	STATOR ASSY 230V 50HZ		1		
039	609024667	LINING RING		1		
040	609024607	SHIM		1		
041	609024608	SKELETON SEAL RING		1	*	
041-1	JH00000111	SKELETON SEAL RING	<	1		
042	609024609	BEARING BOX		1		
043	609024610	O-RING		1	*	
043-1	JH00000112	O-RING	<	1		
044	JH00000055	MOTOR HOUSING LOWER SIDE		1		
045	609024608	SKELETON SEAL RING		1	*	
045-1	JH00000111	SKELETON SEAL RING	<	1		
046	609024633	MECHANICAL SEAL		1	*	
046-1	JH00000127	MECHANICAL SEAL	<	1		
047	609024634	RETAINING RING S-12 INOX		1		
048	609024613	SPACER WASHER 12		1		
049	609024686	IMPELLER		1		
050	609024615	NYLON INSERT HEX LOCK NUT M 8		1		
051	609024612	O-RING		1	*	
051-1	JH00000113	O-RING	<	1		
052	JH00000058	O-RING RETAINER		1		
053	609024646	TAPPING SCREW 4X30 INOX		6		
054	609024654	GROUND PLATE		1		
055	609024655	MOTOR MOUNT		1		
056	609024671	GASKET FOR HOUSING		1	*	
056-1	JH00000120	GASKET FOR HOUSING	<	1		
057	609024690	LOWER HOUSING INOX		1		
058	JH00000005	OUTLET CONNECTOR KIT		1	*	
D10		INC. 59-62				
058-1	JH00000006	OUTLET CONNECTOR KIT	X	1		
D10		INC. 59-62				
059	609024627	OUTLET CONNECTOR		1	*	
059-1	609024693	OUTLET CONNECTOR	X	1		
060	609024625	O-RING		1	*	
060-1	609024692	O-RING	X	1	*	
060-2	JH00000121	O-RING	<	1		
061	609024625	O-RING		1	*	
061-1	609024692	O-RING	X	1	*	
061-2	JH00000121	O-RING	<	1		
062	609024626	ELBOW		1	*	
062-1	609024691	ELBOW	X	1		

Veuillez indiquer les pièces n ° lorsque votre commande.

Date d'impression 06/12/2024