

DESCRIZIONE : LAMA 2 smussi : 2480 x 203 x 19 (15 Fori + Svaso)

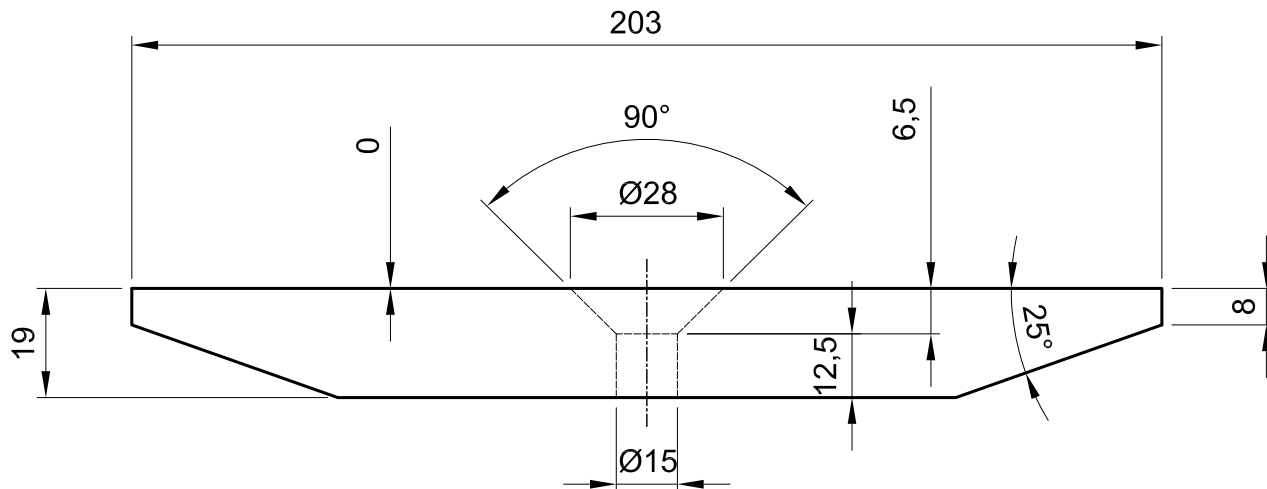
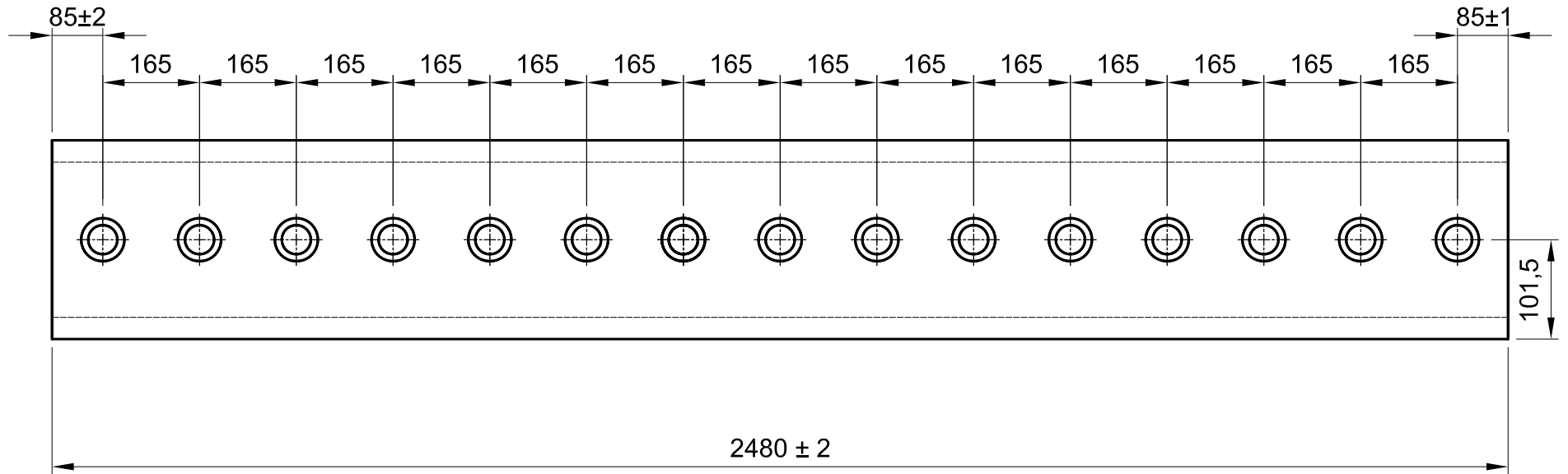

ESTI

CLIENTE	DATA
SASU TOPAZ	29 / 06 / 15
MATERIALE	DISEGNATORE
ESTRONG 500 (HB 500)	BELOTTI
NOSTRO RIFERIMENTO	RIFERIMENTO ORIGINALE
SAS - 03	10420

NOTE : vite M14